

### 1-3 国税庁機構図

平成 25 年度 定員：55,856 人

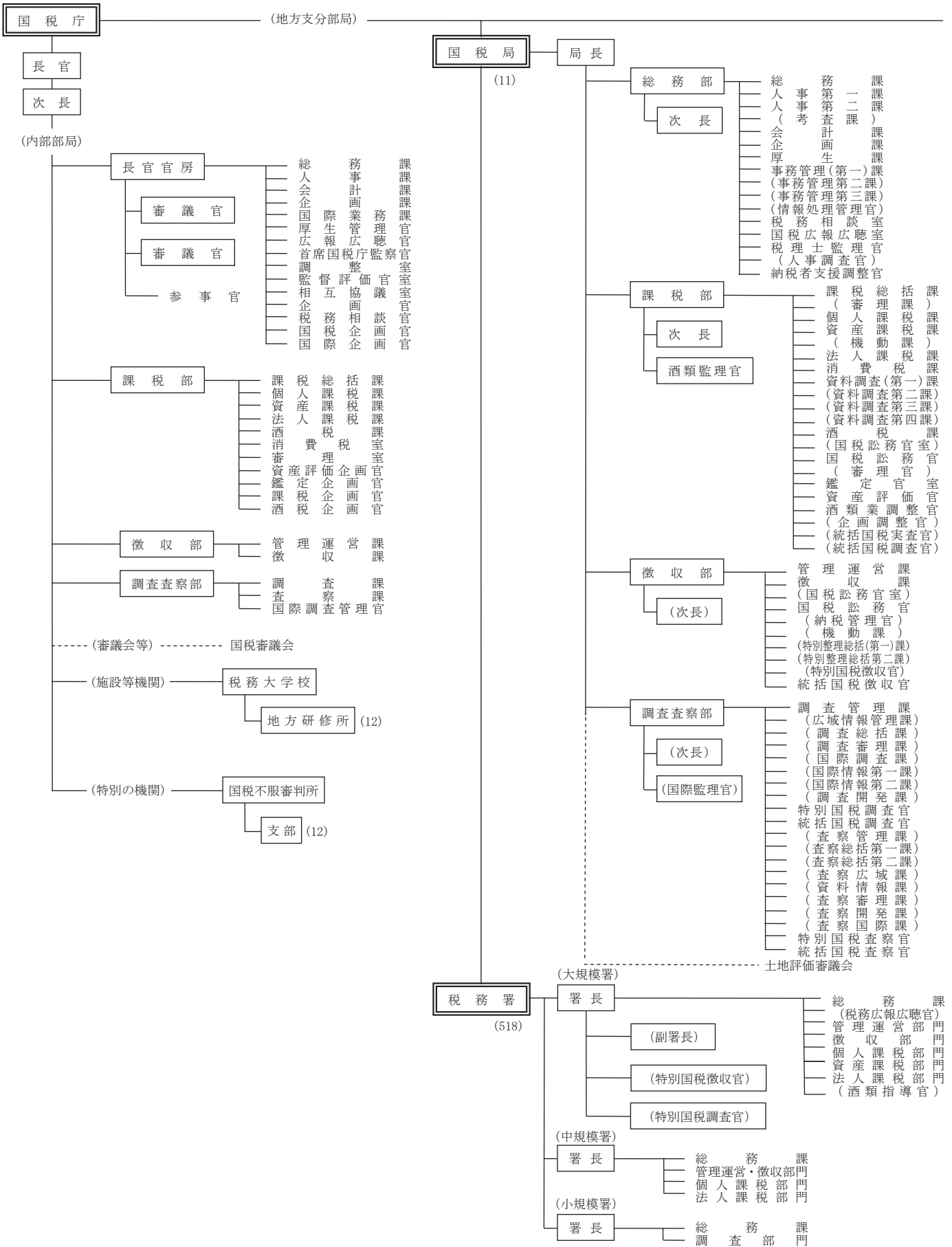

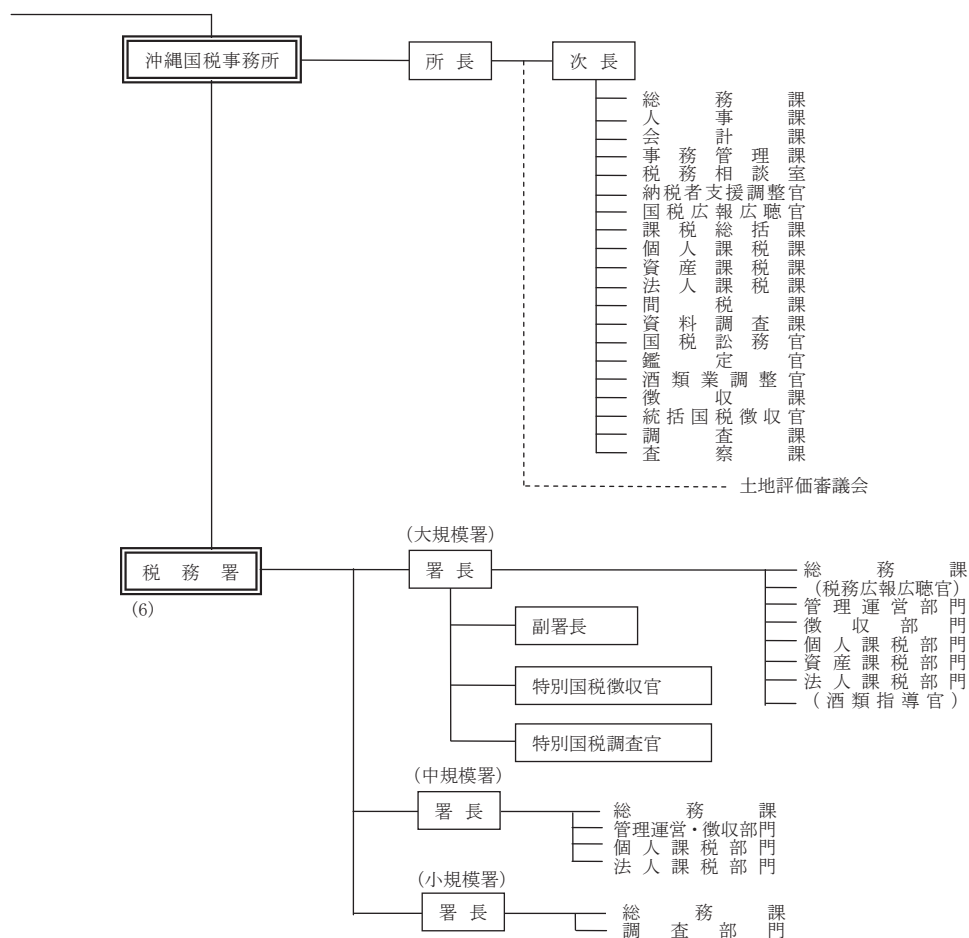

- (注) 1 金沢国税局、高松国税局及び熊本国税局以外の国税局の課税部は、課税第一部、課税第二部に分かれています。
- 2 東京国税局、名古屋国税局及び大阪国税局の調査査察部は、次のとおり分かれています。
- 東京国税局 調査第一部、調査第二部、調査第三部、調査第四部、査察部  
 名古屋国税局 調査部、査察部  
 大阪国税局 調査第一部、調査第二部、査察部
- 3 ( ) 書きの機構は、一部の国税局、税務署に設置されているものを示す。

### 1 - 3 Organization Chart of National Tax Agency

(FY2013) (Number of persons: 55,856)

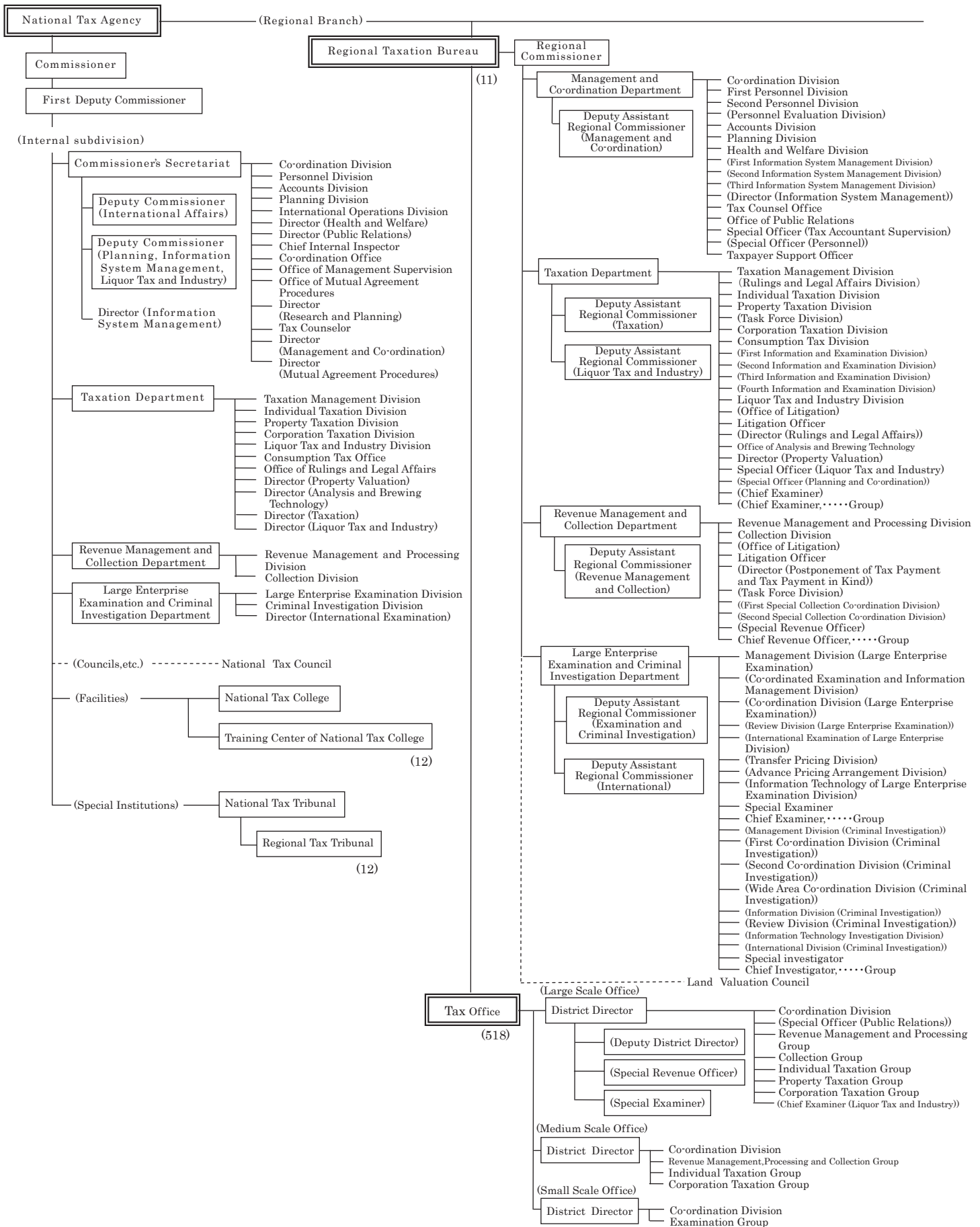

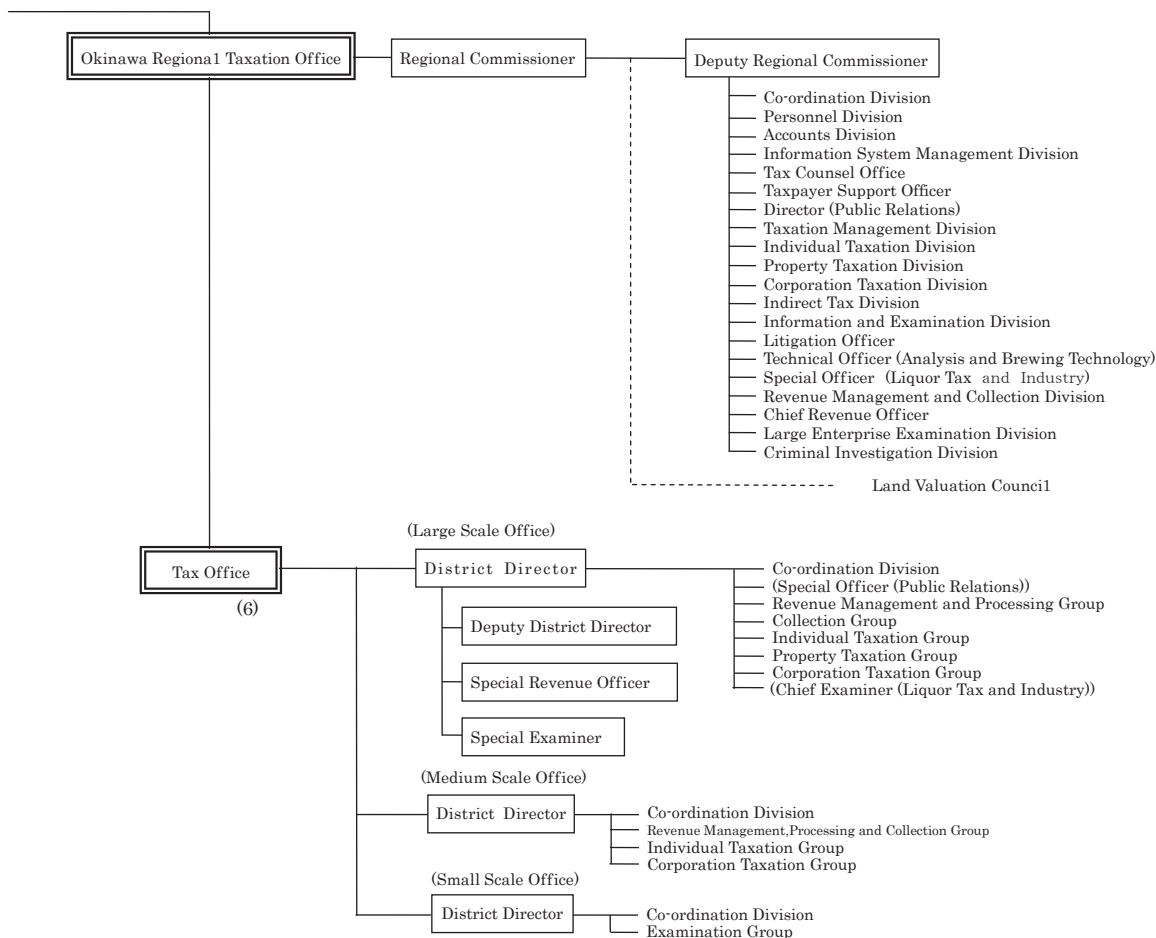

Note:

- 1 The Taxation Departments of Regional Taxation Bureaus other than Kanazawa, Takamatsu, and Kumamoto are composed as follows:  
First Taxation Department, and Second Taxation Department
- 2 The Examination and Criminal Investigation Departments of Tokyo, Nagoya and Osaka Regional Taxation Bureaus are composed as follows:  
Tokyo: First Examination Department, Second Examination Department Third Examination Department, Fourth Examination Department, and Criminal Investigation Department  
Nagoya: Examination Department and Criminal Investigation Department  
Osaka: First Examination Department, Second Examination Department, and Criminal Investigation Department
- 3 Organization of Regional Taxation Bureau and Taxation Office written in brackets are those which are not located in every Bureau/Office.

1-4 管 区 表

Table of District under Jurisdiction

(1) 都道府県別面積、人口、税務署数等

Area, Population, and Number of Taxation offices by prefecture

国税局・都道府県 Regional Taxation Bureau / Prefecture		面 積 Area	世 帯 数 Number of Households	人 口 Population	税務署数 Number of Taxation Offices	市 数 Number of Cities	町 数 Number of Towns	村 数 Number of Villages
		km <sup>2</sup>	千世帯 Thousand	千人 Thousand		Special ward	Ward	(21)
札幌 Sapporo	北海道 Hokkaido	83,424	2,727	5,463	30	35	区 10 129	15
仙台 Sendai	青森 Aomori	9,645	585	1,368	7	10		22
	岩手 Iwate	15,275	516	1,311	9	14		15
	宮城 Miyagi	6,859	951	2,329	10	13	区 5	21
	秋田 Akita	11,638	425	1,070	8	13		9
	山形 Yamagata	6,652	407	1,151	8	13		19
	福島 Fukushima	13,784	760	1,976	10	13		31
	計 Total	66,947	3,644	9,206	52	76	区 5	117
関東信越 Kanto Shinetsu	茨城 Ibaraki	6,097	1,187	2,994	8	32		10
	栃木 Tochigi	6,408	793	2,010	8	14		12
	群馬 Gunma	6,362	808	2,020	9	12		15
	埼玉 Saitama	3,768	3,086	7,289	15	40	区 10	22
	新潟 Niigata	10,364	875	2,355	13	20	区 8	6
	長野 Nagano	13,104	846	2,161	10	19		23
	計 Total	48,811	7,596	18,828	63	137	区 18	88
東京 Tokyo	千葉 Chiba	5,083	2,704	6,248	14	37	区 6	16
	東京 Tokyo	2,106	6,700	13,202	48	23	26	5
	神奈川 Kanagawa	2,416	4,114	9,101	18	19	区 28	13
	山梨 Yamanashi	4,201	350	862	4	13		8
	計 Total	14,229	13,868	29,412	84	23	95	34
金沢 Kanazawa	富山 Toyama	2,046	406	1,092	4	10		4
	石川 Ishikawa	4,186	466	1,163	5	11		8
	福井 Fukui	4,190	285	808	6	9		8
計 Total	12,624	1,157	3,063	15	30		20	
名古屋 Nagoya	岐阜 Gifu	9,769	793	2,098	7	21		19
	静岡 Shizuoka	7,254	1,519	3,803	13	23	区 10	12
	愛知 Aichi	5,123	3,097	7,479	20	38	区 16	14
	三重 Mie	5,759	769	1,869	8	14		15
	計 Total	29,347	6,177	15,249	48	96	区 26	60
大阪 Osaka	滋賀 Shiga	3,767	548	1,422	7	13		6
	京都 Kyoto	4,612	1,176	2,586	13	15	区 11	10
	大阪 Osaka	1,905	4,118	8,879	31	33	区 31	9
	兵庫 Hyogo	8,401	2,460	5,655	21	29	区 9	12
	奈良 Nara	3,691	578	1,403	4	12		15
	和歌山 Wakayama	4,725	438	1,012	7	9		20
	計 Total	27,351	9,318	20,957	83	111	区 51	72
広島 Hiroshima	鳥取 Tottori	3,507	233	587	3	4		14
	島根 Shimane	6,708	285	711	7	8		10
	岡山 Okayama	7,011	817	1,945	13	15	区 4	10
	広島 Hiroshima	8,479	1,273	2,876	16	14	区 8	9
	山口 Yamaguchi	6,112	657	1,443	11	13		6
計 Total	31,922	3,264	7,563	50	54	区 12	49	
高松 Takamatsu	徳島 Tokushima	4,147	330	782	6	8		15
	香川 Kagawa	1,863	427	1,010	6	8		9
	愛媛 Ehime	5,676	645	1,437	8	11		9
	高知 Kochi	7,104	353	754	6	11		17
計 Total	18,804	1,756	3,983	26	38		50	
福岡 Fukuoka	福岡 Fukuoka	4,854	2,296	5,119	18	28	区 14	30
	佐賀 Saga	2,441	321	852	5	10		10
	長崎 Nagasaki	4,132	626	1,425	8	13		8
	計 Total	11,559	3,244	7,396	31	51	区 14	48
熊本 Kumamoto	熊本 Kumamoto	7,272	757	1,826	10	14	区 5	23
	大分 Oita	5,100	526	1,198	9	14		3
	宮崎 Miyazaki	6,794	516	1,142	6	9		14
	鹿児島 Kagoshima	9,044	803	1,703	11	19		20
計 Total	30,673	2,602	5,869	36	56	区 5	60	
沖縄 Okinawa	沖縄 Okinawa	2,281	601	1,448	6	11		11
全国計 Grand Total		377,972	55,952	128,438	524	790	特区 23 区 175	746
								(189)

(注) 1 面積は、国土地理院調べによる(平成26年10月1日現在)。国税局計、全国計が内訳と不適合であるのは、境界未定分を国税局計、全国計に含めたためである。  
 2 世帯数、人口は総務省調べによる(平成26年1月1日現在)。  
 3 税務署数は、平成26年7月10日現在による。  
 4 市、町、村数は、総務省調べによる(平成26年4月1日現在)。  
 5 「市数」及び「町数」欄の「特区」及び「区」の計数は本書には含まれていない。  
 6 ( )内は、北方領土を含んだ計数である。

Note:1 Figures for area are based on the survey by the Geographical Survey Institute, Ministry of Land infrastructure and Transport (as of October 1, 2014). The discrepancy between total by Regional Taxation Bureaus or grand total and total of specific figures comes from the fact that total by Regional Taxation Bureaus or grand total include figures for areas with borders undetermined.  
 2 The numbers of households and population are based on the survey by the Ministry of Internal Affairs and Communications (as of January 1, 2014).  
 3 The numbers of taxation offices as of July 10, 2014, are listed.  
 4 The numbers of cities, towns and villages are based on the survey by the Ministry of Internal Affairs and Communications (as of April 1, 2014).  
 5 Figures for "Special ward" and "ward" in the columns of "Number of Cities" and "Number of Towns" are Extra in this book.  
 6 Figures in brackets include the six villages of the Northern Territories.

(2) 国税局の管轄区域

District under Jurisdiction of Regional Taxation Bureau

名称 Name	所在地 Location
国税庁 National Tax Agency	東京都千代田区霞が関3丁目1番1号 3-1-1 Kasumigaseki, Chiyoda Ku, Tokyo
札幌国税局 Sapporo Regional Taxation Bureau	札幌市中央区大通西10丁目 10 Odori-nishi, Chuo Ku, Sapporo City
仙台国税局 Sendai Regional Taxation Bureau	仙台市青葉区本町3丁目3番1号 3-3-1 Honcho, Aoba Ku, Sendai City
関東信越国税局 Kanto Shinetsu Regional Taxation Bureau	さいたま市中央区新都心1番地1 1-1 Shin-toshin, Chuo Ku, Saitama City
東京国税局 Tokyo Regional Taxation Bureau	東京都中央区築地5丁目3番1号 5-3-1 Tsukiji, Chuo Ku, Tokyo
金沢国税局 Kanazawa Regional Taxation Bureau	金沢市広坂2丁目2番60号 2-2-60 Hirosaka, Kanazawa City
名古屋国税局 Nagoya Regional Taxation Bureau	名古屋市中区三の丸3丁目3番2号 3-3-2 Sannomaru, Naka Ku, Nagoya City
大阪国税局 Osaka Regional Taxation Bureau	大阪市中央区大手前1丁目5番63号 1-5-63 Otemae, Chuo Ku, Osaka City
広島国税局 Hiroshima Regional Taxation Bureau	広島市中区上八丁堀6番30号 6-30 Kami-Hacchobori, Naka Ku, Hiroshima City
高松国税局 Takamatsu Regional Taxation Bureau	高松市天神前2番10号 2-10 Tenjinmae, Takamatsu City
福岡国税局 Fukuoka Regional Taxation Bureau	福岡市博多区博多駅東2丁目11番1号 2-11-1 Hakataeki-higashi, Hakata Ku, Fukuoka City
熊本国税局 Kumamoto Regional Taxation Bureau	熊本市西区春日2丁目10番1号 2-10-1 Kasuga, Nishi Ku, Kumamoto City
沖縄国税事務所 Okinawa Regional Taxation Office	那覇市旭町9番地 9 Asahicho, Naha City

